

2-Piece Direct Mount Ball Valves

Mounting flanged ball valves are manufactured with flanges compatible with ISO5211 direct actuator mounting and in anti-static design with ATEX approval.

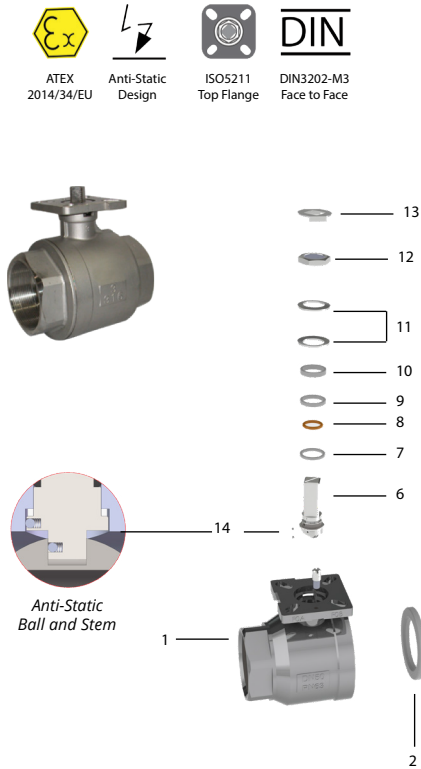

Pressure-Temperature Diagram

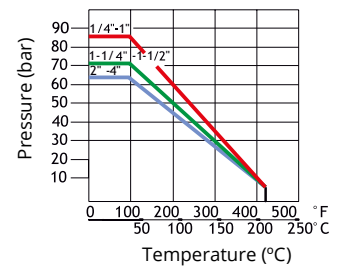

Material List

No	Part Name	Material	Qty	No	Part Name	Material	Qty	No	Part Name	Material	Qty
1	Body	AISI304 / AISI316	1	6	Stem	AISI304 / AISI316	1	11	Belleville Washer	AISI304	2
2	Ball Seal	PTFE	2	7	Thrust Washer	PTFE	1	12	Nut	AISI304	1
3	Ball	AISI304 / AISI316	1	8	O-Ring	Viton	1	13	Locking Washer	AISI304	1
4	Body Seal	PTFE	1	9	Stem Packing	PTFE	1	14	Anti-Static Device	AISI316	2
5	Cap	AISI304 / AISI316	1	10	Packing Ring	AISI304	1				

Dimensions (mm)

Size (DN)	d	L	h	K	C	ISO5211 Top Flange	Torque (N.m)	Kv (m ³ /h)	Weight (Kg)
1/2"	15	75	37	8,7	9	F03/F04	5	35	0,37
3/4"	20	80	42,2	8,8	11	F03/F04	8	46	0,49
1"	25	90	45,5	10,7	11	F04/F05	10	72	0,74
1-1/4"	32	110	54	10,5	14	F04/F05	14	105	1,18
1-1/2"	40	120	59,5	14	14	F05/F07	18	170	1,94
2"	50	140	67,5	13,5	7	F05/F07	25	275	2,90
2-1/2"	65	185	93	18,5	17	F07/F10	48	507	5,77
3"	76	205	109	17,5	17	F07/F10	75	905	8,45
4"	94	240	121	20,5	17	F07/F10	110	1414	15,60

